

EPB

Elevated Post Base

Material: EPB44A — 14 gauge; others — 12 gauge base plate, 1 1/8" OD x 8" pipe

Finish: EPB44A — Galvanized; all others — Simpson Strong-Tie gray paint (may be ordered HDG)

Installation:

- Use all specified fasteners; see General Notes
- Allows 1" to 2 1/2" clearance above concrete, 2" for EPB44A
- Post bases do not provide adequate resistance to prevent members from rotating about the base and therefore are not recommended for non-top-supported installations (such as fences or unbraced carports)

Options:

- 12" pipe available for EPB44, 46, 66; specify "-12" after model number

Codes: See p. 13 for Code Reference Key Chart

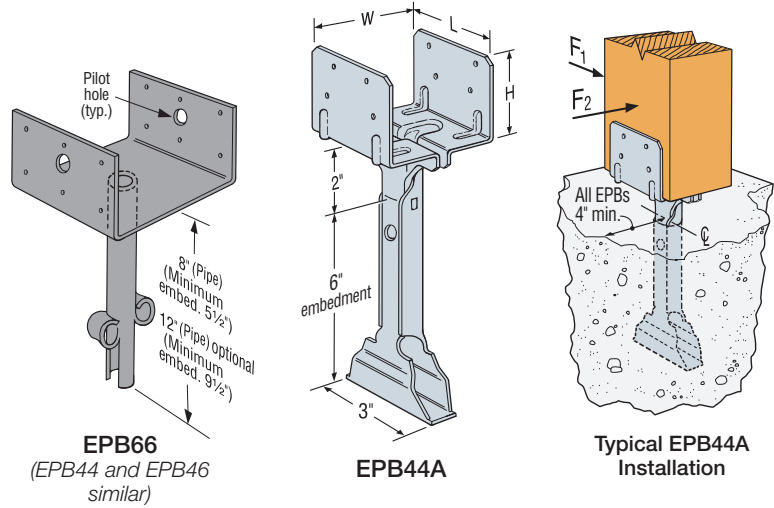

These products are available with additional corrosion protection. For more information, see p. 16.

SD Many of these products are approved for installation with Strong-Drive® SD Connector screws. See pp. 362–366 for more information.

Model No.	Dimensions (in.)			Nails	Allowable Loads					Code Ref.	
	W	L	H		Uncracked	Cracked	Download	F ₁	F ₂		
					Uplift (160)	Uplift (160)	(100)	(160)	(160)		
Wind and Seismic Design Category A&B											
EPB44A	3 5/16	3	2 3/8	(8) 0.162 x 3 1/2	1,075	755	2,670	695	795	IBC®, FL, LA	
EPB44	3 5/16	3 1/4	2 5/16	(8) 0.162 x 3 1/2	995	695	3,465	850	965		
EPB46	5 1/2	3 5/16	3	(12) 0.162 x 3 1/2	995	695	3,465	850	965		
EPB66	5 1/2	5 1/2	3	(12) 0.162 x 3 1/2	995	695	3,465	850	965		
Seismic Design Category C–F											
EPB44A	3 5/16	3	2 3/8	(8) 0.162 x 3 1/2	940	660	2,670	695	795	IBC, FL, LA	
EPB44	3 5/16	3 1/4	2 5/16	(8) 0.162 x 3 1/2	870	605	3,465	850	965		
EPB46	5 1/2	3 5/16	3	(12) 0.162 x 3 1/2	870	605	3,465	850	965		
EPB66	5 1/2	5 1/2	3	(12) 0.162 x 3 1/2	870	605	3,465	850	965		

1. Loads may not be increased for duration of load.
2. Concrete shall have a minimum compressive strength of $f'_c = 2,500$ psi.
3. Multiply seismic and wind ASD uplift and lateral load values by 1.43 or 1.67, respectively, to obtain LRFD capacities.
4. In accordance with IBC, Section 1613.1, detached one- and two-family dwellings in Seismic Design Category (SDC) C may use "Wind and SDC A&B" allowable loads.
5. Downloads shall be reduced where limited by capacity of the post.
6. Designer is responsible for concrete design.
7. For full loads, the distance to the nearest concrete edge is 4" minimum from the EPB center line.
8. Structural composite lumber columns have sides that show either the wide face or the edges of the lumber strands/veneers known as the narrow face. Values in the tables reflect installation into the wide face. See technical bulletin T-C-SCLCLM at strongtie.com for load reductions resulting from narrow-face installations.
9. **Fasteners:** Nail dimensions are listed diameter by length. See pp. 23–24 for fastener information.

EPB44PHDG

Elevated Post Base

EPB44PHDG can be used both for pier block and cast-in-place installation for 4x4 posts.

Material: 12-gauge base; threaded rod support 3/4" x 6", nut and washer are shipped assembled

Finish: HDG

Installation:

- Secured with Anchoring Adhesive:**
 Drill a 7/8"-diameter hole 4" deep minimum and fill the hole halfway with anchoring adhesive (per installation instructions). Insert the EPB44PHDG and adjust to the desired height. The threaded rod shall be embedded a minimum of 3 1/2". Minimum sidecover is 3" from the center of the threaded rod.
- Go to strongtie.com for additional information on hole cleaning procedures and cure time for SET-3G™ and AT-3G™ anchoring adhesives.
- Supported by a Nut:**
 Drill a 1"-diameter hole 3 1/2" deep minimum. Insert the EPB44PHDG and adjust to the desired height.
- Cast-in-Place:**
 Embedded end to have a nut and bearing plate with a minimum embedment of 4" from top of concrete to the top of plate.
- Minimum sidecover is 3" from the center of the threaded rod.
- Fully engage at least three threads in the base.
- Post bases do not provide adequate resistance to prevent members from rotating about the base and therefore are not recommended for non-top-supported installations (such as fences or unbraced carports).

Codes: See p. 13 for Code Reference Key Chart

These products are available with additional corrosion protection. For more information, see p. 16.

SD Many of these products are approved for installation with Strong-Drive® SD Connector screws. See pp. 362–366 for more information.

Model No.	Nails (in.)	Anchor Bolt	DF/SP Allowable Loads				Code Ref.
			Download (100)		Uplift (160)		
			Adhesive or Cast-in-Place	Support by a Nut	SET-3G	AT-3G	
EPB44PHDG	(8) 0.162 x 3 1/2	3/4	3,625	760	1,265	985	—

- Loads may not be increased for duration of load.
- Uplift loads require the threaded rod to be attached to cured concrete with SET-3G or AT-3G anchoring adhesive. Cast-in-place installations must have a nut and bearing plate embedded in concrete. Uplift loads do not apply when installed to a pier block.
- Designer is responsible for concrete design.
- Downloads shall be reduced where limited by capacity of the post.
- Structural composite lumber columns have sides that show either the wide face or the edges of the lumber strands/veneers. For SCL columns, the fasteners for these products should always be installed in the wide face. See technical bulletin T-C-SCLCLM at strongtie.com for load reductions resulting from narrow-face installations.
- Adhesive anchor design assumptions:
 - Uncracked dry concrete
 - Anchors not for use in SDC C–F where load combinations include earthquake load
 - Temperature range: Maximum short term temperature = 176°F, Maximum long term temperature = 110°F
 - Periodic special inspection assumed per code report
 - Minimum concrete strength of 2,500 psi.
- Fasteners:** Nail dimensions are listed diameter by length. See pp. 23–24 for fastener information.

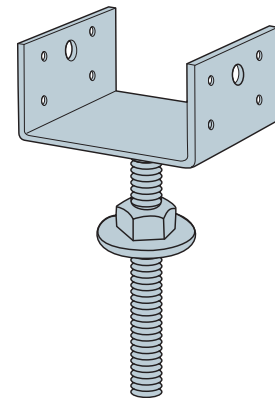

EPB44PHDG

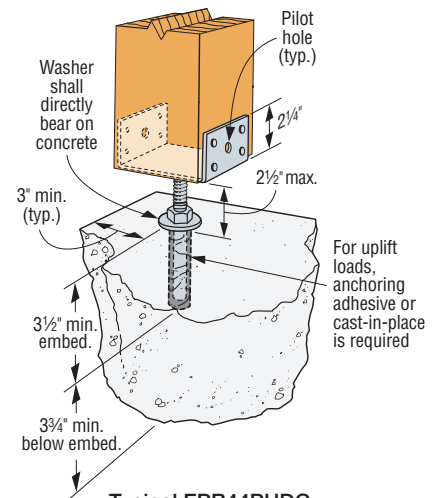

Typical EPB44PHDG Installed with SET-3G or AT-3G Anchoring Adhesive

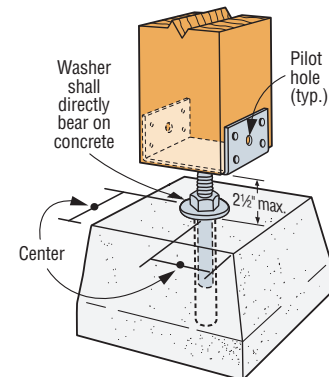

Typical EPB44PHDG Pier Block Installation (supported by a nut)