

ECCLQ/CCCQ/CCTQ

Column Caps

The ECCLQ, CCCQ and CCTQ column caps provide strong, multiple beam-to-column connector options. The design uses Strong-Drive® SDS Heavy-Duty Connector screws to provide faster installation and a lower profile compared to standard through bolts. Screws are configured to provide high uplift design values.

Material: CCCQ3, ECCLQ3, CCTQ3, CCCQ4, ECCLQ4, CCTQ4, CCCQ4.62, ECCLQ4.62, CCTQ4.62, CCCQ6, ECCLQ6, CCTQ6 — 7 gauge; all others — 3 gauge

Finish: Simpson Strong-Tie gray paint; also available in HDG

Installation:

- Install ¼" x 2½" Strong-Drive SDS Heavy-Duty Connector screws, which are provided, in all round holes. (Lag screws will not achieve the same load.)
- No additional welding is allowed.

Options:

- Many combinations of beam and post sizes can be manufactured; use [Post-to-Beam Selector web application at app.strongtie.com/pbs](https://app.strongtie.com/pbs) to specify dimensions for ordering.
- Available in widths up to 8" wide.
- ECCLQ is available in left or right side beam orientations. Specify ECCLLQ or ECCLRQ.
- Straps may be rotated where $W_1 \geq W_2$.
- Column caps may be ordered without the column straps for field welding to a steel column, full loads apply for the beam and the post cap. Specify "No Straps" when ordering. Weld by designer. These models have no coating.

Ordering:

- The L dimension varies depending on the width of the side stirrup (W_3 or W_4). Contact Simpson Strong-Tie for exact dimensions.
- Main beam stirrup height (H_1) is 7". Side beam stirrups (H_2 or H_3) can vary in height with the minimum height of 7". Specify the side stirrup height from the top of the cap.
- Example Order: 4x main beam, 6x post, 4x side beam (oriented to the left) with both beams flush on bottom is ordered as an ECCLLQ464SDS.

Codes: See p. 13 for Code Reference Key Chart

Web Applications: Visit app.strongtie.com/pbs to access our Post-to-Beam Selector web application.



Series	DF/SP Allowable Loads					Code Ref.
	Uplift (160)			Download (100)		
	Main Beam	Side Beam	Total	Side Beam	Total	
ECCLQ-SDS	2,835	1,840	3,795	6,780	Refer to note #5	—
CCCQ-SDS	4,780	2,390	4,780	7,000		
CCTQ-SDS	4,910	2,350	5,315	7,000		

1. Uplift loads have been increased for earthquake or wind loading with no further increase allowed. Reduce where other loads govern.
2. Allowable load is per seat. Side beams must be loaded symmetrically for the CCCQ.
3. The combined uplift loads applied to all beams in the connector must not exceed the total allowable uplift load listed in the table.
4. The ECCLQ side beam may use a side beam uplift load up to 2,350 lb. The deflection of this load may exceed the standard ⅛" deflection by an additional ⅛".
5. The combined download for all the carried beams shall not exceed the allowable download for the unmodified product on p. 93 (CCQ load for CCCQ and CCTQ, or ECCQ load for ECCLQ). The download for each side beam shall not exceed the allowable load shown.
6. Column width in the direction of the beam width must be the same as the main beam width (W_1).

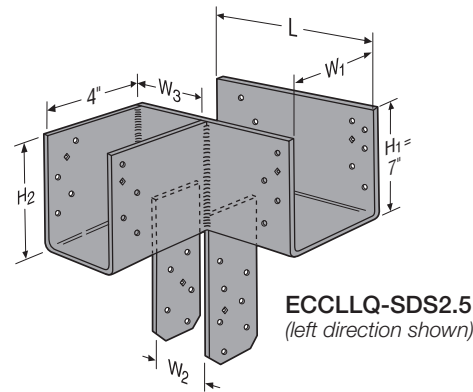

ECCLLQ-SDS2.5
(left direction shown)

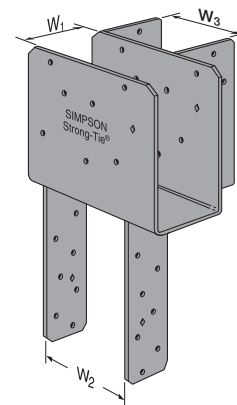

ECCLRQ-SDS2.5
(right direction shown)

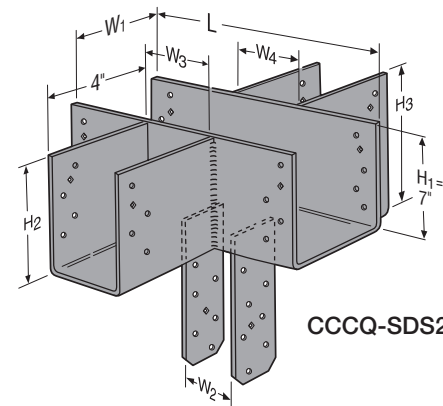

CCCQ-SDS2.5

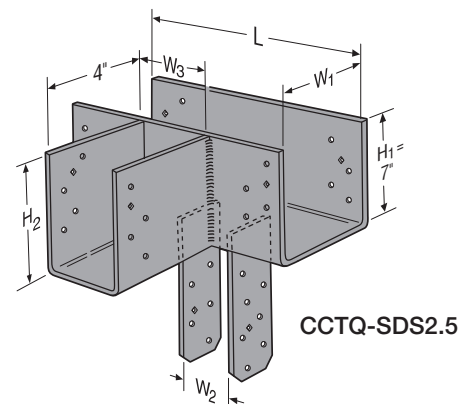

CCTQ-SDS2.5