

MSSC4.25KW and MSSC6.25KW Kneewall Connectors

Rigid Connectors

MSSC connectors are designed to work in tandem with Simpson Strong-Tie® BP½-3 bearing plates to provide solutions for moment-resisting kneewall lighter-duty applications.

Features:

- One simple custom hole pattern for each stud size simplifies specification and installation
- 3/8" diameter anchor bolt location enables easy tool access

Material: MSSC — 97 mil (50 ksi); BP — 229 mil (33 ksi)

Finish: MSSC — Galvanized (G90); BP — None

Installation:

- Use all specified fasteners/anchors
- Install BP½-3 bearing plate over anchor leg of MSSC connectors as shown in the illustrations

Codes: See p. 13 for Code Reference Key Chart

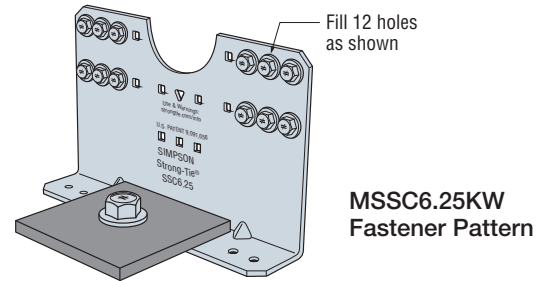
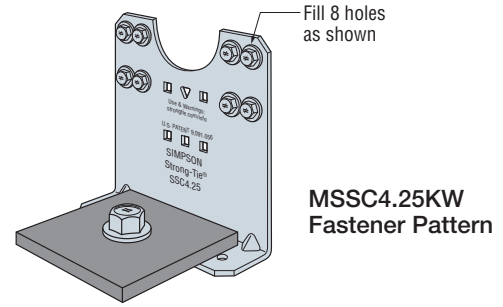

Ordering Information

Model No.	Ordering SKU	Package Quantity
MSSC4.25KW	MSSC4.25KW-KT20	Box of 20 connectors and 20 BP bearing plates
MSSC6.25KW	MSSC6.25KW-KT20	

Allowable Loads

Model No.	Connector Material Thickness mil (ga.)	L (in.)	Framing Member Depth (in.)	Fasteners ⁵		Stud Thickness mil (ga.)	Allowable Moment, M (in.-lb.) ¹	Anchor Tension at Allowable Moment (lb.) ²	Rotational Stiffness for Wind Deflection (in.-lb./rad.) ^{3,4}	Code Ref.
				Anchor Diameter (in.)	Stud					
MSSC4.25KW	97 (12)	4¼	6	3/8	(8) #10	33 (20)	3,135	1,610	64,800	IBC, LA
						43 (18)	4,320	2,305 ⁵		
						54 (16)	5,830	3,300 ⁵		
MSSC6.25KW	97 (12)	6¼	8	3/8	(12) #10	33 (20)	3,845	1,290	110,350	IBC, LA
						43 (18)	3,845	1,290		
						54 (16)	8,350	2,980 ⁵		

1. Tabulated values correspond to maximum connector strength without consideration of serviceability. Designer must check out-of-plane deflections using tabulated rotational stiffness.
2. Uplift may be linearly interpolated for design moment less than allowable. Designer is responsible for anchorage design.
3. Tabulated stiffness is applicable for walls up to 38" tall. For taller walls, the designer must consider additional deflection due to bending in the studs.
4. Per IBC 2015 Table 1604.3 footnote f, wind load is permitted to be taken as 0.42 times "component and cladding loads" for deflection checks. For IBC 2009 and earlier, the factor is 0.7 instead of 0.42.
5. Tabulated allowable tension loads for the connectors with 3/8"-diameter anchor bolts require ASTM F3125 Grade A325 or ASTM A449 high-strength bolts. For A307 Grade A bolt, anchor tension load is limited to 2,200 lb.
6. See the current *Fastening Systems* catalog at strongtie.com for more information on Simpson Strong-Tie fasteners.

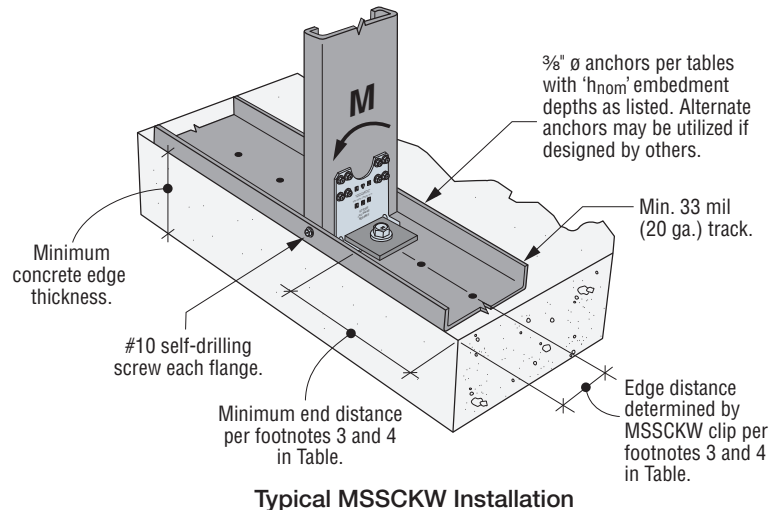

MSSC4.25KW and MSSC6.25KW Kneewall Connectors

Kneewall Connector Anchorage Solutions

Uncracked Concrete, Wind and Seismic in SDC A & B ^{8,10}									
Model No.	Minimum Concrete Thickness (h _{min})	¾"-Diameter Simpson Strong-Tie® Anchor Type	Nominal Embedment Depth (h _{nom}) (in.)	Allowable Moment, M (in.-lb.)					
				Edge of Slab ³			Center of Slab ⁴		
				3,000 psi SLWC	3,000 psi NWC	4,000 psi NWC	3,000 psi SLWC	3,000 psi NWC	4,000 psi NWC
MSSC4.25KW	4" or thicker	Strong Bolt® 2	2¼	—	—	—	1,220	2,040	2,365
		Titen HD®	2½	1,255	2,090	2,425	1,255	2,090	2,425
	6" or thicker	Strong Bolt 2	2⅞	—	—	—	1,555	2,590	2,995
		Titen HD	3¼	1,795	2,995	3,450	2,075	3,465	3,995
		SET-3G™	4	725	1,425	1,425	1,930	3,705	3,705
	Concrete thickness ≥ 9.5"	AT-XP®	4	750	1,470	1,470	2,005	3,705	3,705
SET-3G		7½	670	1,320	1,320	3,610	3,705	3,705	
AT-XP	7½	695	1,360	1,360	3,690	3,705	3,705		
	MSSC6.25KW	4" or thicker	Strong Bolt 2	2¼	—	—	—	1,515	2,530
Titen HD			2½	1,555	2,590	3,005	1,555	2,590	3,005
6" or thicker		Strong Bolt 2	2⅞	—	—	—	1,930	3,215	3,715
		Titen HD	3¼	2,570	4,295	4,950	2,570	4,295	4,950
		SET-3G	4	1,110	2,170	2,170	2,395	4,595	4,595
Concrete thickness ≥ 9.5"		AT-XP	4	1,135	2,235	2,235	2,480	4,595	4,595
	SET-3G	7½	1,030	2,015	2,015	4,480	4,595	4,595	
AT-XP	7½	1,055	2,065	2,065	4,575	4,595	4,595		

See footnotes on p. 132.

Cracked Concrete, Wind and Seismic in SDC A & B ^{8,10}									
Model No.	Minimum Concrete Thickness (h _{min})	¾"-Diameter Simpson Strong-Tie® Anchor Type	Nominal Embedment Depth (h _{nom}) (in.)	Allowable Moment, M (in.-lb.)					
				Edge of Slab ³			Center of Slab ⁴		
				3,000 psi SLWC	3,000 psi NWC	4,000 psi NWC	3,000 psi SLWC	3,000 psi NWC	4,000 psi NWC
MSSC4.25KW	4" or thicker	Strong Bolt 2	2¼	—	—	—	860	1,435	1,660
		Titen HD	2½	575	955	1,100	575	955	1,100
	6" or thicker	Strong Bolt 2	2⅞	—	—	—	1,295	2,150	2,495
		Titen HD	3¼	1,255	2,095	2,430	1,255	2,095	2,430
		SET-3G	4	1,175	2,305	2,305	1,485	2,915	2,915
	Concrete thickness ≥ 9.5"	AT-XP	4	1,220	2,395	2,395	1,560	3,065	3,065
SET-3G		7½	2,200	3,705	3,705	2,790	3,705	3,705	
AT-XP	7½	2,290	3,705	3,705	2,935	3,705	3,705		
MSSC6.25KW	4" or thicker	Strong Bolt 2	2¼	—	—	—	1,070	1,780	2,055
		Titen HD	2½	715	1,185	1,365	715	1,185	1,365
	6" or thicker	Strong Bolt 2	2⅞	—	—	—	1,605	2,665	3,090
		Titen HD	3¼	1,555	2,600	3,010	1,555	2,600	3,010
		SET-3G	4	1,795	3,505	3,505	1,840	3,615	3,615
	Concrete thickness ≥ 9.5"	AT-XP	4	1,860	3,645	3,645	1,935	3,800	3,800
SET-3G		7½	3,350	4,595	4,595	3,455	4,595	4,595	
AT-XP	7½	3,490	4,595	4,595	3,640	4,595	4,595		

See footnotes on p. 132.

MSSC4.25KW and MSSC6.25KW Kneewall Connectors

Kneewall Connector Anchorage Solutions (cont.)

Cracked Concrete, Seismic in SDC C through F ^{9,10}									
Model No.	Minimum Concrete Thickness (h _{min})	%"-Diameter Simpson Strong-Tie® Anchor Type	Nominal Embedment Depth (h _{nom}) (in.)	Allowable Moment, M (in.-lb.)					
				Edge of Slab ³			Center of Slab ⁴		
				3,000 psi SLWC	3,000 psi NWC	4,000 psi NWC	3,000 psi SLWC	3,000 psi NWC	4,000 psi NWC
MSSC4.25KW	4" or thicker	Strong Bolt® 2	2¼	—	—	—	300	500	580
		Titen HD®	2½	200	335	385	200	335	385
	6" or thicker	Strong Bolt 2	2¾	—	—	—	450	755	870
		Titen HD	3¼	440	735	850	440	735	850
		SET-3G™	4	410	805	805	520	1,020	1,020
		AT-XP®	4	430	840	840	550	1,070	1,070
	Concrete thickness ≥ 9.5"	SET-3G	7½	770	1,495	1,495	975	4,325	4,325
AT-XP		7½	800	1,575	1,575	1,025	4,325	4,325	
MSSC6.25KW	4" or thicker	Strong Bolt 2	2¼	—	—	—	375	620	720
		Titen HD	2½	250	415	480	250	415	480
	6" or thicker	Strong Bolt 2	2¾	—	—	—	560	935	1,080
		Titen HD	3¼	545	910	1,050	545	910	1,050
		SET-3G	4	625	1,225	1,225	645	1,265	1,265
		AT-XP	4	650	1,275	1,275	680	1,330	1,330
	Concrete thickness ≥ 9.5"	SET-3G	7½	1,180	5,360	5,360	1,210	5,360	5,360
		AT-XP	7½	1,220	5,310	5,310	1,270	5,310	5,310

- Allowable Moments have been determined using ACI 318-14 Chapter 17 anchorage calculations with the minimum concrete compressive strength, f_c and slab thickness listed. Sand-Lightweight Concrete is abbreviated as 'SLWC', Normal Weight Concrete is abbreviated as 'NWC'.
- Nominal Embedment Depth/Effective Embedment Depth relationships:
 - ¾" Titen HD in 4" concrete: 2.50" (h_{nom}) / 1.77" (h_{ef})
 - ¾" Titen HD in 6" concrete: 3.25" (h_{nom}) / 2.40" (h_{ef})
 - ¾" carbon steel Strong-Bolt 2 into 4" concrete: 2.25" (h_{nom}) / 1.875" (h_{ef})
 - ¾" carbon steel Strong-Bolt 2 into 6" concrete: 2.875" (h_{nom}) / 2.5" (h_{ef})
 - SET-3G or AT-XP adhesive with ¾" F1554 Gr. 36 all-thread rod in 6" concrete: 4.0" (h_{nom}) = 4" (h_{ef})
 - SET-3G or AT-XP adhesive with ¾" F1554 Gr. 36 all-thread rod in 9.5" concrete: 7.5" (h_{nom}) = 7.5" (h_{ef})
- At edge of slab, edge distances are assumed to be 3.0" and 4.0" (½ of stud width) as determined for 6" and 8" studs, respectively. 'End distances' are assumed as 1.5 x Min. Edge Distance in one direction and 'N/A' in the other direction. See figure on p. 130.
- At center of slab, edge and end distances are assumed as 'N/A' in all directions at locations away from edge of slab. See figure on p. 130.
- Load values are for a single anchor based on ACI 318-14, condition B, load factors from ACI 318-14 Section 5.3, no supplemental edge reinforcement, $\Psi_{c,v} = 1.0$ for cracked concrete and periodic special inspection. Reference ICC-ES or IAPMO-UES evaluation reports for further information.
- Load values are based on a short-term temperature range of 160°F and 180°F for SET-3G and AT-XP. Long-term temperature range is assumed to be 110°F for both SET-3G and AT-XP. Dry hole conditions are assumed. Other conditions may be evaluated using Anchor Designer™ Software for ACI 318, ETAG and CSA. See strongtie.com/software.
- Allowable Stress Design (ASD) values were determined by multiplying calculated LRFD capacities by a conversion factor, Alpha (α), of 0.7 for seismic loads and 0.6 for wind loads. ASD values for other load combinations may be determined using alternate conversion factors.
- Tabulated allowable ASD loads for Wind and Seismic in SDC A&B are based on using wind conversion factors and may be increased by 1.17 for SDC A&B only.
- Allowable loads have been divided by an Omega (Ω) seismic factor of 2.5 for brittle failure as required by ACI 318-14 Chapter 17, unless steel failure governs.
- Tabulated allowable moments are for MSSC Kneewall Connectors attached to studs with 33 (20) or 43 (18) mil (ga.) thickness. Allowable moment may be increased for MSSC Kneewall Connectors attached to studs with 54 (16) mil (ga.) thickness by multiplying by a factor of 1.16 for MSSC4.25KW and 1.28 for MSSC6.25KW.
- Tabulated capacities assume lateral force applied at height of 38" above concrete. Tabulated capacities are based on maximum allowable anchorage loads only. The capacity of the connection system shall be the minimum of the tabulated value and the allowable load value from the MSSCKW Connectors: Allowable Load Tables.