

DSP/SSP/SP/SPH/RSP4/TSP/CS

Stud Plate Ties



This product is preferable to similar connectors because of (a) easier installation, (b) higher loads, (c) lower installed cost, or a combination of these features.

The stud plate tie series offers general solutions for connecting the stud to the top and bottom plates. All models can be used to make a connection to either the top or bottom plate, and several are suitable for double top plates and studs.

Material: DSP/SSP/SPH — 18 gauge;
TSP/CS16 — 16 gauge; all others — 20 gauge

Finish: Galvanized. Some products available in ZMAX® coating.

Installation:

- Use all specified fasteners; see General Notes.
- TSP/DSP/SSP — Sill-plate installation: fill all round holes.
- TSP/DSP/SSP — Top-plate installation: fill all round and triangle holes.
- SP1/SP2 — One of the 0.148" x 3" stud nails is driven at a 45° angle through the stud into the plate.
- CS — Slide the CS16 or CS20 strap underneath the mudsill with the appropriate length of strap protruding from the inside of the mudsill. See illustration on p. 292 for more details.
 - Each bend in the strap must be tight, and the strap must sit flush against the edge of the mudsill and the stud or sheathing.
 - Bend strap one time only.

Codes: See p. 13 for Code Reference Key Chart

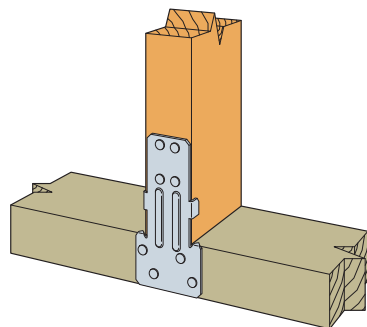
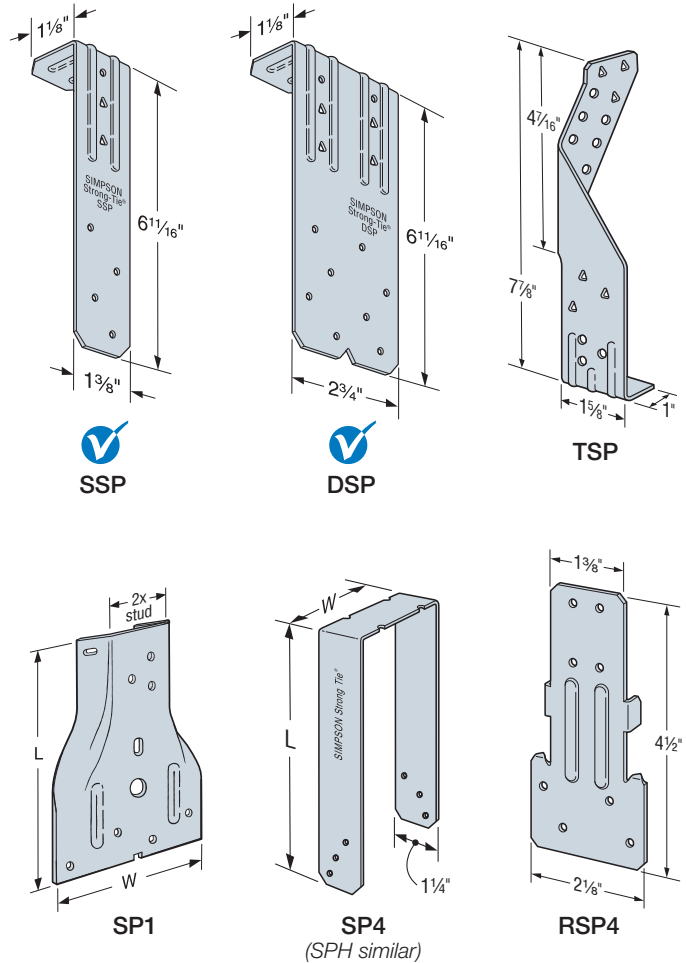

(1) Typical RSP4
Stud to Single Bottom Plate

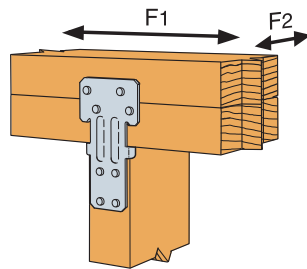

(2) Typical RSP4
Stud to Double Top Plate
(see footnote 4)

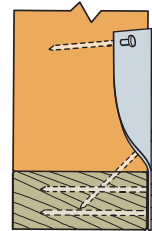

SP1 Nailing
Profile

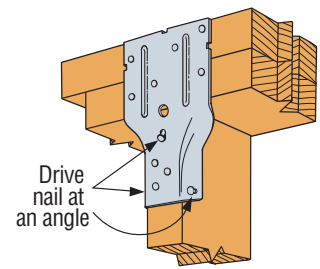

Typical SP2 Installation

DSP/SSP/SP/SPH/RSP4/TSP/CS

Stud Plate Ties (cont.)

These products are available with additional corrosion protection. For more information, see p. 16.

SS For stainless-steel fasteners, see p. 23.

SD Many of these products are approved for installation with Strong-Drive® SD Connector screws. See pp. 362–366 for more information.

Model No.	Dimensions (in.)		Stud	Plate Width	Fasteners (in.)		Allowable Uplift Loads				Code Ref.
	W	L			Stud	Plate	DF/SP		SPF/HF		
							Side ⁸ (160)	Center ⁹ (160)	Side ⁸ (160)	Center ⁹ (160)	
SP1	3½	5⅞	2x	—	(6) 0.148 x 3	(4) 0.148 x 3	555	555	535	535	IBC®, FL, LA
SP2	3½	6⅝	2x	—	(6) 0.148 x 3	(6) 0.148 x 3	1,010	1,010	605	605	
SP4	3⅞	7¼	2x	4x	(6) 0.148 x 1½	—	415	825	355	710	
SP6	5⅞	7¾	2x	6x	(6) 0.148 x 1½	—	415	825	355	710	
SP8	7⅞	8⅝	2x	8x	(6) 0.148 x 1½	—	415	825	355	710	
SPH4	3⅞	8¾	2x	4x	(10) 0.148 x 1½	—	520	1,040	450	895	
					(12) 0.148 x 1½	—	600	1,200	515	1,030	
SPH6	5⅞	9¼	2x	6x	(10) 0.148 x 1½	—	520	1,040	450	895	
					(12) 0.148 x 1½	—	600	1,200	515	1,030	
SPH8	7⅞	8⅝	2x	8x	(10) 0.148 x 1½	—	520	1,040	450	895	
					(12) 0.148 x 1½	—	600	1,200	515	1,030	
RSP4 (1)	2⅞	4½	2x	—	(4) 0.131 x 1½	(4) 0.131 x 1½	245	245	285	285	
RSP4 (2)	2⅞	4½	2x	—	(4) 0.131 x 1½	(4) 0.131 x 1½	390	390	370	370	
CS20	1¼	24	2x	—	(6) 0.148 x 1½	—	—	550	—	475	
				—	(10) 0.148 x 1½	—	—	915	—	790	
SS CS16	1¼	26	2x	—	(12) 0.148 x 1½	—	—	1,135	—	980	
				—	(14) 0.148 x 1½	—	—	1,325	—	1,140	

- See pp. 276–277 for Straps and Ties General Notes.
- SP1/SP2 — drive one stud nail at an angle through the stud into the plate to achieve the table load (see illustration).
- RSP4 — see Installation details (1) and (2) for reference.
- RSP4 — F₂ is 225 lb. for Installation 1 and 245 lb. for Installation 2. F₁ load is 165 lb. for both installations.
- Maximum load for SPH in southern yellow pine is 1,415 lb. for center loading and 710 lb. for side loading.
- When cross-grain bending or cross-grain tension cannot be avoided in the members, mechanical reinforcement to resist such forces shall be considered by the designer.
- For retrofit application, use CS16 and CS20. Total length of strap and total nail quantity are listed.
- Use Side (eccentric) load when uplift loads are applied to only one face of the top plate.
- Use Center (concentric) loads when uplift loads are applied at the centerline of the top plate, or where equal loads are applied to both sides of the top plate. Center loads should also be used for stud-to-bottom plate loads.
- Order SPH4R and SPH6R for installation over ½" sheathing with a maximum DF/SP load of 1,360 lb. for center loading.
- Fasteners:** Nail dimensions are listed diameter by length. See pp. 23–24 for fastener information.

Straps and Ties

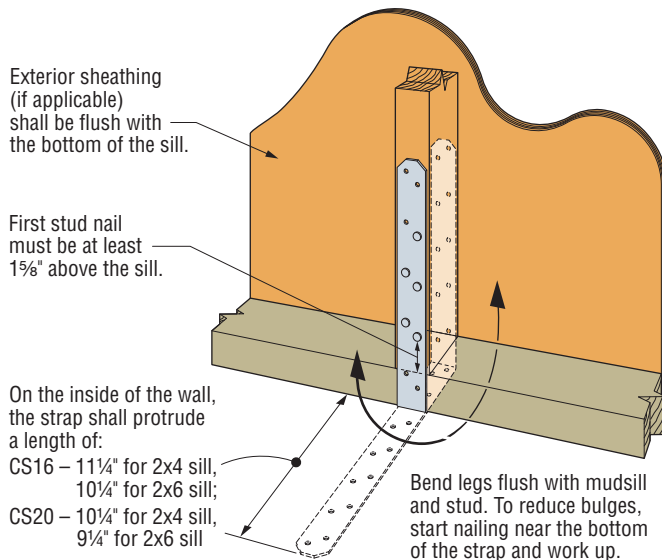

Typical CS Installation Stud to Mudsill

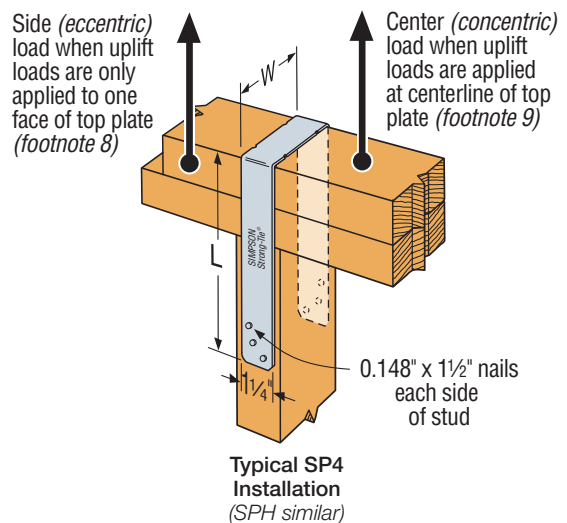

DSP/SSP/SP/SPH/RSP4/TSP/CS

Stud Plate Ties (cont.)

These products are available with additional corrosion protection. For more information, see p. 16.

Model No.	Dimensions (in.)		Fasteners (in.)			Allowable Uplift Loads (160)			Code Ref.
	W	L	Studs	Double Top Plate	Single Sill Plate	Double Top Plate	Single Sill Plate		
						DF/SP/SPF	DF/SP	SPF/HF	
SSP	1¾	6 11/16	(4) 0.148 x 1 1/2	(3) 0.148 x 1 1/2	—	330	—	—	IBC®, FL, LA
			(4) 0.148 x 3	—	(1) 0.148 x 1 1/2	—	395	310	
DSP	2¾	6 11/16	(8) 0.148 x 1 1/2	(6) 0.148 x 1 1/2	—	730	—	—	
			(8) 0.148 x 3	—	(2) 0.148 x 1 1/2	—	620	515	
			—	(6) 0.148 x 3	—	780	—	—	
			—	—	(2) 0.148 x 3	—	780	565	
TSP	1 1/2	7 7/8	(6) 0.148 x 1 1/2	—	(3) 0.148 x 1 1/2	—	465 ⁵	400	
			(9) 0.148 x 1 1/2	(6) 0.148 x 1 1/2	—	755 ⁴	—	—	
				(6) 0.148 x 3	—	1,015 ⁴	—	—	

- See pp. 276–277 for Straps and Ties General Notes.
- When cross-grain bending or cross-grain tension cannot be avoided in the members, mechanical reinforcement to resist such forces shall be considered by the designer.
- Allowable loads for DSP installed to a rim board are 620 lb. (DF/SP) and 515 lb. (SPF/HF).
- Noted values apply only to DF/SP members. For SPF values, multiply by 0.86.
- Southern pine allowable uplift load is 520 lb.
- Fasteners:** Nail dimensions are listed diameter by length. See pp. 23–24 for fastener information.

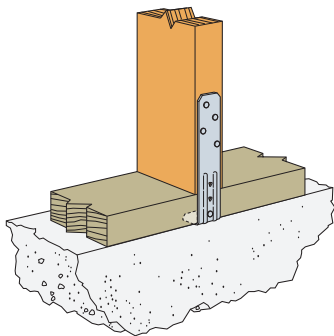

Typical SSP
Installed to Sill Plate
(DSP similar for double stud)

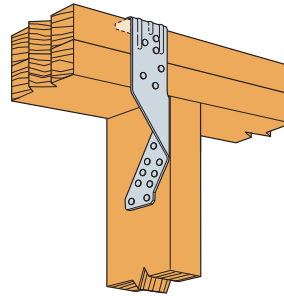

Typical TSP Installed
to Top Plate

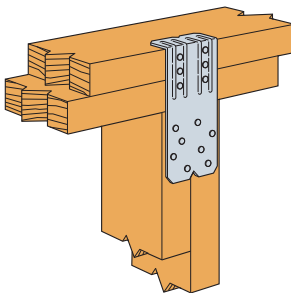

Typical DSP
Installed to Top Plate
(SSP similar for single stud)

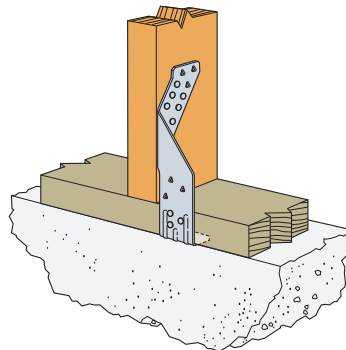

Typical TSP Installed
to Sill Plate

SP Stud Plate Ties

The SP stud plate tie is a plate-to-stud connection providing uplift resistance.

Material: See table.

Finish: Galvanized. Available with ZMAX® coating; see Corrosion Information, pp. 19–23.

Installation: Use all specified fasteners

Codes: See p. 13 for Code Reference Key Chart

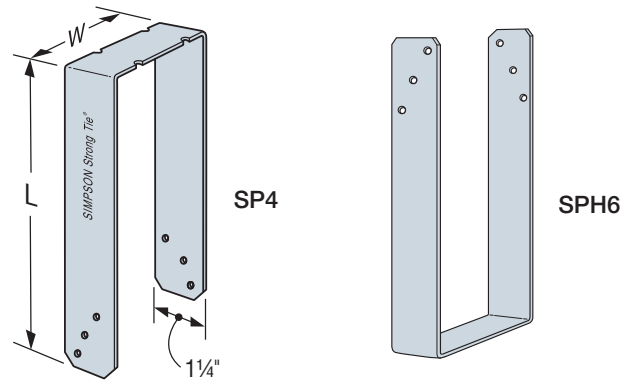

These products are available with additional corrosion protection. Additional products on this page may also be available with this option. Check with Simpson Strong-Tie for details.

Model No.	Connector Material Thickness mil (ga.)	Dimensions (in.)		Stud Fasteners ¹	Allowable Uplift Load 33 mil (20 ga.) (lb.)	Code Ref.
		W	L			
SP4	33 (20)	3 ⁵ / ₁₆	7 ¹ / ₄	(6) #10	825	IBC, FL, LA
SP6	33 (20)	5 ⁵ / ₁₆	7 ³ / ₄	(6) #10	825	
SP8	43 (18)	7 ⁵ / ₁₆	8 ⁵ / ₁₆	(6) #10	930	—
SPH4	43 (18)	3 ⁵ / ₁₆	8 ³ / ₄	(12) #10	1,490	
SPH4R	43 (18)	4 ¹ / ₁₆	8 ¹ / ₄	(12) #10	1,490	
SPH6	43 (18)	5 ⁵ / ₁₆	9 ¹ / ₄	(12) #10	1,490	
SPH6R	43 (18)	6 ¹ / ₁₆	8 ³ / ₄	(12) #10	1,490	
SPH8	43 (18)	7 ⁵ / ₁₆	8 ³ / ₈	(12) #10	1,490	

1. See the current *Fastening Systems* catalog at strongtie.com for more information on Simpson Strong-Tie fasteners.

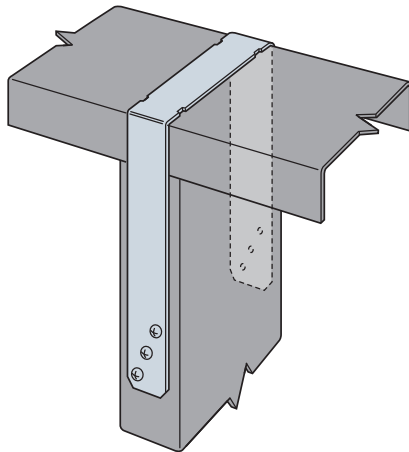

Typical SP Installation
(Wall-to-Top Track)

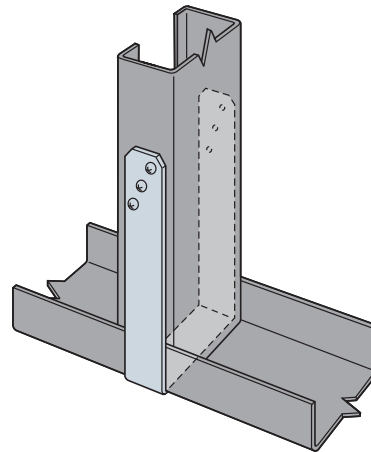

Typical SP Installation
(Wall-to-Bottom Track)
(SPH similar)