

# THA/THAC

## Adjustable Truss Hangers



*This product is preferable to similar connectors because of (a) easier installation, (b) higher loads, (c) lower installed cost, or a combination of these features.*

The THA series have extra long straps that can be field-formed to give height adjustability and top-flange hanger convenience. THA hangers can be installed as top-flange or face-mount hangers.

THA4x and THA2x-2 models feature a dense nail pattern in the straps, which provides more installation options and allows for easy top-flange installation.

**Material:** See table

**Finish:** Galvanized. Some products available in ZMAX® coating or HDG.

**Installation:**

- Use all specified fasteners; see General Notes.

**The following installation methods may be used:**

- **Top-Flange Installation** — The straps must be field-formed over the header 2" minimum (27/16" for the THA29). Install top and face nails according to the table. Top nails shall not be within 1/4" from the edge of the top-flange members. For top-flange (min.) installations (not applicable to the THA29), straighten the double-shear nailing tabs and install the nails straight into the joist. For top-flange (max.) installations, nails used for joist attachment must be driven at an angle so that they penetrate through the joist and into the header (requires full backing), and the lowest four face holes must be filled.
  - **Face-Mount (Min.) Installation** — Install face nails according to the table, with at least half of the required fasteners in the top half of the header. Not all nail holes in the straps will be filled. Nails must have a minimum 1/2" edge distance. Straighten the double-shear nailing tabs and install the joist nails straight into the joist. The face-mount (min.) installation option accommodates conditions where the supported member hangs either partially or entirely below the header.
  - **Face-Mount (Max.) Installation** — Install face nails according to the table. Not all nail holes in the straps will be filled except for the following models: THA29, THA213, THA218 and THA413. For all other models with more nail holes than required, the straps may be installed straight or wrapped over the header, with the tabulated quantity of face nails installed into the face and top of the header. The lowest four face holes must be filled. Nails used for the joist attachment must be driven at an angle so that they penetrate through the corner of the joist into the header.
  - **Uplift** — Lowest face nails must be filled to achieve uplift loads.
- Options:**
- THA hangers available with the header flanges turned in for 3/8" (except THA413) and wider, with no load reduction — order THAC hanger.

**Codes:** See p. 13 for Code Reference Key Chart

**Web Applications:** Visit [app.strongtie.com/hs](http://app.strongtie.com/hs) to access our Hanger Selector web application.

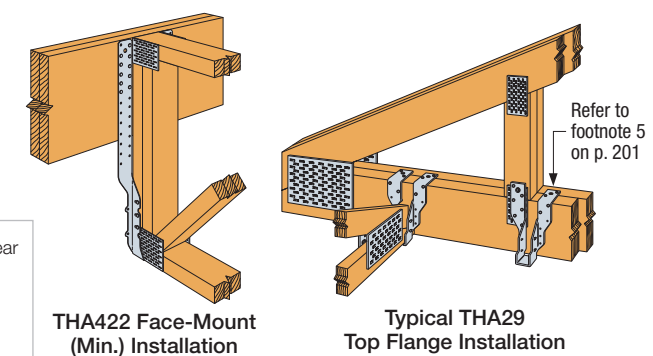
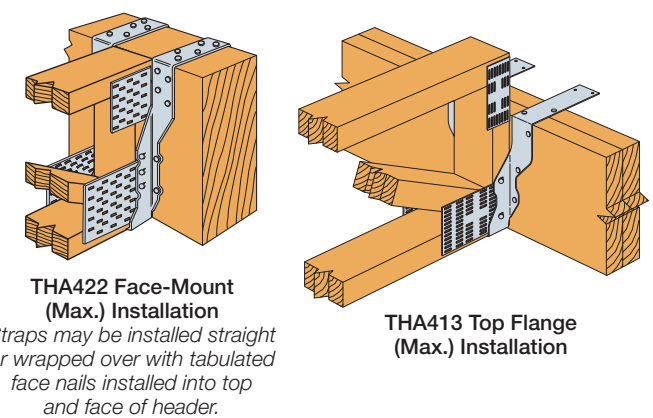
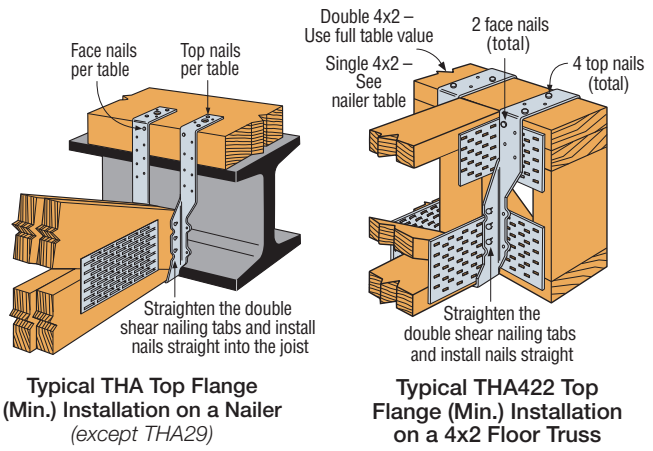
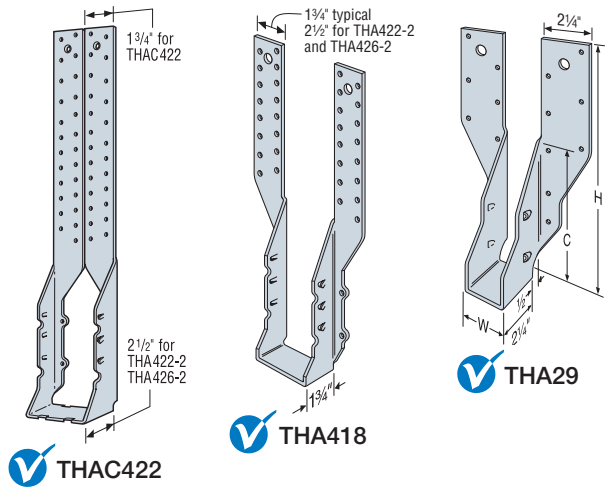
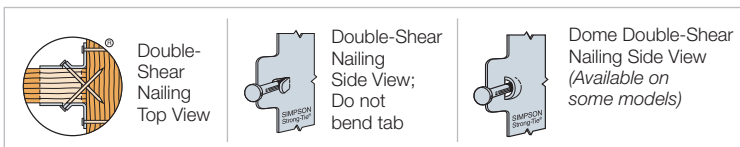

Plated Truss Connectors

C-C-2024 © 2024 SIMPSON STRONG-TIE COMPANY INC.

# THA/THAC

## Adjustable Truss Hangers (cont.)

These products are available with additional corrosion protection. For more information, see p. 16.

Model No.	Ga.	Dimensions (in.)			Min. Header Depth (in.)	Fasteners (in.)			DF/SP Allowable Loads					SPF/HF Allowable Loads					Code Ref.
		W	H	C		Carrying Member		Carried Member	Uplift (160)	Floor (100)	Snow (115)	Roof (125)	Wind (160)	Uplift (160)	Floor (100)	Snow (115)	Roof (125)	Wind (160)	
						Top	Face												
<b>Top-Flange Installation<sup>3</sup></b>																			
THA29 Max.	18	1½	9¼	5½	5½	(4) 0.148 x 3	(6) 0.148 x 3	(4) 0.148 x 3	465	2,560	2,560	2,560	2,560	405	2,040	2,040	2,040	2,040	
THA213 Min.	18	1½	13¾	5½	—	(4) 0.148 x 3	(2) 0.148 x 3	(4) 0.148 x 1½	—	1,430	1,430	1,430	1,430	—	1,170	1,170	1,170	1,170	
THA213 Max.					7¾	(4) 0.148 x 3	(6) 0.148 x 3	(4) 0.148 x 3	855	2,090	2,090	2,090	2,090	750	1,620	1,620	1,620	1,620	
THA218 Min.	18	1½	17¾	5½	—	(4) 0.148 x 3	(2) 0.148 x 3	(4) 0.148 x 1½	—	1,430	1,430	1,430	1,430	—	1,170	1,170	1,170	1,170	
THA218 Max.					7¾	(4) 0.148 x 3	(6) 0.148 x 3	(4) 0.148 x 3	855	2,090	2,090	2,090	2,090	750	1,620	1,620	1,620	1,620	
THA218-2 Min.	16	3½	17¼	8	—	(4) 0.162 x 3½	(2) 0.162 x 3½	(6) 0.148 x 3	—	2,245	2,245	2,245	2,245	—	1,835	1,835	1,835	1,835	
THA218-2 Max.					11¼	(4) 0.162 x 3½	(6) 0.162 x 3½	(6) 0.162 x 3½	1,855	3,670	3,670	3,670	3,670	1,670	2,790	2,790	2,790	2,790	
THA222-2 Min.	16	3½	22¾	8	—	(4) 0.162 x 3½	(2) 0.162 x 3½	(6) 0.148 x 3	—	2,245	2,245	2,245	2,245	—	1,835	1,835	1,835	1,835	
THA222-2 Max.					11¼	(4) 0.162 x 3½	(6) 0.162 x 3½	(6) 0.162 x 3½	1,855	3,670	3,670	3,670	3,670	1,615	2,790	2,790	2,790	2,790	
THA413 Min.	18	3½	13¾	4½	—	(4) 0.148 x 3	(2) 0.148 x 3	(4) 0.148 x 3	—	1,430	1,430	1,430	1,430	—	1,055	1,055	1,055	1,055	
THA413 Max.					7¼	(4) 0.148 x 3	(6) 0.148 x 3	(4) 0.148 x 3	855	2,090	2,090	2,090	2,090	750	1,620	1,620	1,620	1,620	
THA418 Min.	16	3½	17½	7¾	—	(4) 0.162 x 3½	(2) 0.162 x 3½	(6) 0.148 x 3	—	2,245	2,245	2,245	2,245	—	1,835	1,835	1,835	1,835	
THA418 Max.					11¼	(4) 0.162 x 3½	(6) 0.162 x 3½	(6) 0.162 x 3½	1,855	3,670	3,670	3,670	3,670	1,670	2,790	2,790	2,790	2,790	
THA422 Min.	16	3½	22	7¾	—	(4) 0.162 x 3½	(2) 0.162 x 3½	(6) 0.148 x 3	—	2,245	2,245	2,245	2,245	—	1,835	1,835	1,835	1,835	
THA422 Max.					11¼	(4) 0.162 x 3½	(6) 0.162 x 3½	(6) 0.162 x 3½	1,855	3,670	3,670	3,670	3,670	1,670	2,790	2,790	2,790	2,790	
THA426 Min.	14	3½	26	7¾	—	(4) 0.162 x 3½	(4) 0.162 x 3½	(6) 0.162 x 3½	—	2,870	2,870	2,870	2,870	—	2,270	2,270	2,270	2,270	
THA426 Max.					11¼	(4) 0.162 x 3½	(6) 0.162 x 3½	(6) 0.162 x 3½	1,855	3,755	3,755	3,755	3,755	1,670	2,945	2,945	2,945	2,945	
THA422-2 Min.	14	7¼	22¼	9¾	—	(4) 0.162 x 3½	(4) 0.162 x 3½	(6) 0.162 x 3½	—	3,330	3,330	3,330	3,330	—	2,465	2,465	2,465	2,465	
THA422-2 Max.					11¼	(4) 0.162 x 3½	(8) 0.162 x 3½	(6) 0.162 x 3½	1,855	4,210	4,210	4,210	4,210	1,670	3,285	3,285	3,285	3,285	
THA426-2 Min.	14	7¼	26¼	9¾	—	(4) 0.162 x 3½	(4) 0.162 x 3½	(6) 0.162 x 3½	—	3,330	3,330	3,330	3,330	—	2,465	2,465	2,465	2,465	
THA426-2 Max.					11¼	(4) 0.162 x 3½	(8) 0.162 x 3½	(6) 0.162 x 3½	1,855	4,210	4,210	4,210	4,210	1,670	3,285	3,285	3,285	3,285	
<b>Face-Mount (Max.) Installation<sup>4</sup></b>																			
THA29	18	1½	9¼	5½	9¼	—	(16) 0.148 x 3	(4) 0.148 x 3	465	2,295	2,305	2,305	2,305	405	1,965	2,250	2,250	2,250	
THA213	18	1½	13¾	5½	13¾	—	(14) 0.148 x 3	(4) 0.148 x 3	855	2,060	2,210	2,210	2,210	750	1,760	2,020	2,145	2,145	
THA218	18	1½	17¾	5½	17¾	—	(18) 0.148 x 3	(4) 0.148 x 3	855	2,210	2,210	2,210	2,210	750	2,145	2,145	2,145	2,145	
THA218-2	16	3½	17¼	8	14¼	—	(22) 0.162 x 3½	(6) 0.162 x 3½	1,855	3,695	3,695	3,695	3,695	1,670	3,330	3,535	3,535	3,535	
THA222-2	16	3½	22¾	8	14¼	—	(22) 0.162 x 3½	(6) 0.162 x 3½	1,855	3,695	3,695	3,695	3,695	1,670	3,330	3,535	3,535	3,535	
THA413	18	3½	13¾	4½	13¾	—	(14) 0.148 x 3	(4) 0.148 x 3	855	2,060	2,210	2,210	2,210	750	1,760	2,020	2,145	2,145	
THA418	16	3½	17½	7¾	14¼	—	(22) 0.162 x 3½	(6) 0.162 x 3½	1,855	3,695	3,695	3,695	3,695	1,670	3,330	3,535	3,535	3,535	
THA422	16	3½	22	7¾	14¼	—	(22) 0.162 x 3½	(6) 0.162 x 3½	1,855	3,695	3,695	3,695	3,695	1,670	3,330	3,535	3,535	3,535	
THA426	14	3½	26	7¾	16¼	—	(30) 0.162 x 3½	(6) 0.162 x 3½	1,855	4,315	4,315	4,315	4,315	1,670	3,225	3,225	3,225	3,225	
THA422-2	14	7¼	22¼	9¾	16¾	—	(30) 0.162 x 3½	(6) 0.162 x 3½	1,855	5,170	5,520	5,520	5,520	1,670	4,440	5,010	5,010	5,010	
THA426-2	14	7¼	26¼	9¾	18	—	(38) 0.162 x 3½	(6) 0.162 x 3½	1,855	5,520	5,520	5,520	5,520	1,670	5,010	5,010	5,010	5,010	

Plated Truss Connectors

IBC®, FL, LA

IBC, FL, LA

- Uplift loads have been increased for earthquake or wind loading with no further increase allowed. Reduce where other loads govern.
- Wind (160) is a download rating.
- Top flange installation loads are based on a minimum two-ply 2x carrying member. For top flange (min.) installation on 4x2 truss carrying members with double top chords, use the specified fasteners for full tabulated values; for single 4x2 top chord or nailer applications, refer to the Nailer Table.
- Face-mount installation loads are based on a two-ply 2x carrying member minimum. For single 2x carrying members, use 0.148" x 1½" nails in the carrying member and tabulated fasteners in the carried member, and use 0.80 of the table value for 18 gauge, and 0.68 of the table value for 16 gauge and 14 gauge.
- For the THA 2x models, one strap may be installed vertically according to the face-mount nailing requirements and the other strap wrapped over the truss chord according to the top-flange (min.) nailing requirements (see drawing on p. 200) and achieve full tabulated top flange (min.) installation loads.
- Refer to installation instructions regarding fastener installation into carried (joist) member. Based on the installation condition, nails will be installed either straight with straightened double-shear nailing tabs or slanted.
- THA29 may be installed on a single 2x6 or 2x8 carrying member using (2) 0.148" x 3" top nails, (6) 0.148" x 3" face nails and (4) 0.148" x 3" slant nails with an allowable download of 2,020 lb. for DF/SP and 1,500 lb. for SPF/HF.
- Fasteners:** Nail dimensions are listed diameter by length. See pp. 23–24 for fastener information.

# THA/THAC

## Adjustable Truss Hangers (cont.)

### Nailer Table

Model No.	Nailer	Top Nailing (in.)	Face Nailing (in.)	Joist Nailing (in.)	Allowable Loads (100/115/125)	
					DF/SP	SPF/HF
THA218-2/ THA222-2	2x	(4) 0.148 x 1 1/2	(2) 0.148 x 1 1/2	(6) 0.148 x 1 1/2	1,335	1,245
		(4) 0.148 x 1 1/2	(2) 0.162 x 3 1/2	(6) 0.162 x 3 1/2	1,415	1,245
	(2) 2x	(4) 0.148 x 3	(2) 0.148 x 3	(6) 0.148 x 3	1,835	1,680
	4x	(4) 0.162 x 3 1/2	(2) 0.162 x 3 1/2	(6) 0.148 x 3	2,245	1,930
THA418/ THA422	2x	(4) 0.148 x 1 1/2	(2) 0.148 x 1 1/2	(6) 0.148 x 1 1/2	1,335	1,245
		(4) 0.148 x 1 1/2	(2) 0.162 x 3 1/2	(6) 0.162 x 3 1/2	1,415	1,245
	(2) 2x	(4) 0.148 x 3	(2) 0.148 x 3	(6) 0.148 x 3	1,735	1,680
	4x	(4) 0.162 x 3 1/2	(2) 0.162 x 3 1/2	(6) 0.148 x 3	2,245	1,930
THA426	2x	(4) 0.148 x 1 1/2	(2) 0.148 x 1 1/2	(6) 0.148 x 1 1/2	1,785	1,360
		(4) 0.148 x 1 1/2	(2) 0.162 x 3 1/2	(6) 0.162 x 3 1/2	2,255	1,940
	(2) 2x	(4) 0.148 x 3	(2) 0.148 x 3	(6) 0.148 x 3	1,735	1,680
	4x	(4) 0.162 x 3 1/2	(4) 0.162 x 3 1/2	(6) 0.162 x 3 1/2	2,435	2,095
THA422-2/ THA426-2	2x	(4) 0.148 x 1 1/2	(2) 0.148 x 1 1/2	(6) 0.148 x 1 1/2	1,375	1,325
		(8) 0.148 x 1 1/2	(2) 0.162 x 3 1/2	(6) 0.162 x 3 1/2	2,345	2,015
	(2) 2x	(4) 0.148 x 3	(4) 0.148 x 3	(6) 0.148 x 3	1,970	1,970
	4x	(4) 0.162 x 3 1/2	(4) 0.162 x 3 1/2	(6) 0.162 x 3 1/2	3,330	2,865

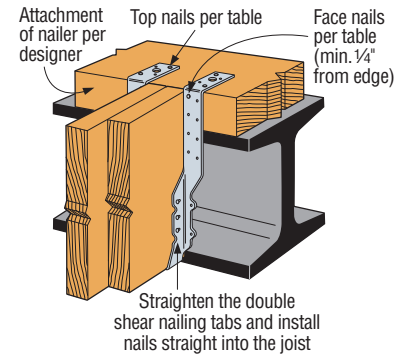
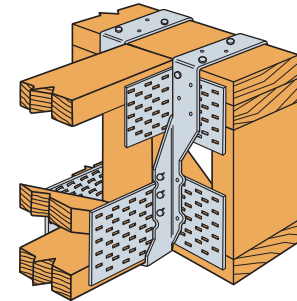

- Loads for 2x Nailers are applicable to single 4x2 top chord carrying members provided:
  - the hanger is located at a top chord panel point; 2) there is no splice at that panel point location;
  - the floor truss girder must have adequate lateral bracing to prevent excessive displacement due to secondary torsional stresses (refer to ANSI/TPI 1-2014, Section 7.5.3.5).
- Attachment of nailer to supporting member is the responsibility of the designer.
- Refer to table on p. 201 for hanger dimensions, minimum top flange requirements and additional footnotes.

### Allowable Loads for Face-Mount (Min.) Nailing Installation

Model No.	Ga.	Dimensions (in.)		Fasteners (in.)		Allowable Loads (lb.)					
		W	H	Header (Face) <sup>3</sup>	Joist	DF/SP			SPF/HF		
						Floor (100)	Snow (115)	Roof (125)	Floor (100)	Snow (115)	Roof (125)
THA213	18	1 1/2	13 3/16	(10) 0.148 x 3	(4) 0.148 x 1 1/2	1,180	1,200	1,200	1,020	1,160	1,200
THA218	18	1 1/2	17 3/16	(10) 0.148 x 3	(4) 0.148 x 1 1/2	1,180	1,200	1,200	1,020	1,160	1,200
THA218-2	16	3 1/2	17 1/16	(20) 0.148 x 3	(6) 0.148 x 1 1/2	2,440	2,485	2,485	2,100	2,140	2,140
THA222-2	16	3 1/2	22 3/16	(20) 0.148 x 3	(6) 0.148 x 1 1/2	2,440	2,485	2,485	2,100	2,140	2,140
THA413	18	3 1/2	13 3/16	(10) 0.148 x 3	(4) 0.148 x 1 1/2	1,180	1,200	1,200	1,020	1,160	1,200
THA418	16	3 1/2	17 1/2	(20) 0.148 x 3	(6) 0.148 x 1 1/2	2,440	2,485	2,485	2,100	2,140	2,140
THA422	16	3 1/2	22	(20) 0.148 x 3	(6) 0.148 x 1 1/2	2,440	2,485	2,485	2,100	2,140	2,140
THA426	14	3 1/2	26	(30) 0.148 x 3	(6) 0.148 x 1 1/2	3,225	3,225	3,225	2,770	2,770	2,770

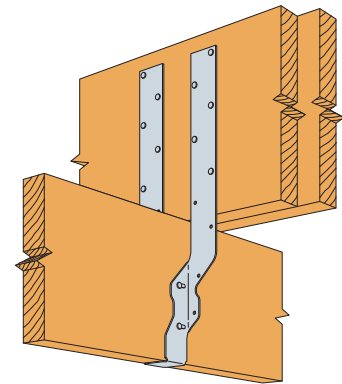

- Loads are based on a min. 2-ply 2x carrying member. 0.148" x 2 1/2" nails may be used instead of the specified 10d commons at 1.00 of the table load. For single-ply 2x or 1 3/4" wide carrying members, use 0.148" x 1 1/2" nails and use 0.77 of the table value. Alternately, #9 x 1 1/2" Strong-Drive® SD Connector screws may be used in place of the specified header and joist nails for full table loads.
- The joist nails should be installed straight into the carried member by straightening the THA double shear nailing tabs. When used to support 2x4 joists, the THA213 or THA218 may be installed with (2) 0.148" x 1 1/2" nails into the joist (one each side).
- At least half of the face fasteners must be installed into the upper half of the header, unless some other means of mechanical reinforcement is used to resist the tension perpendicular to grain stresses. Nails must have a minimum 1/2" edge distance.
- For installations with fewer face fasteners than specified, reduce the allowable load as follows: Allowable load = No. of Face Nails Used/No. Face Nails in Table x Table Load.
- Fasteners:** Nail dimensions are listed diameter by length. SD screws are Simpson Strong-Tie Strong-Drive SD Connector screws. See pp. 23-24 for fastener information.



Visit [app.strongtie.com/hs](http://app.strongtie.com/hs) to access our Hanger Selector web application.